

alegra

## Instructions for use



CE  
0297



**Turbine handpieces with LED**

TE-97 LQ / TE-98 LQ

**Quick coupling with generator**

RQ-53 / RQ-54

**Turbine handpieces without light**

TE-95 BC / TE-95 RM

TE-97 / TE-97 BC / TE-97 RM

TE-98 / TE-98 BC / TE-98 RM

# Contents

---

<b>Symbols</b> .....	4
<b>1. Introduction</b> .....	6
<b>2. Safety notes</b> .....	10
<b>3. Product description</b> .....	14
Quick coupling with generator .....	14
Turbine TE-97 LQ / TE-98 LQ .....	16
Turbine TE-97 / TE-98.....	17
Turbine TE-95 BC / TE-97 BC / TE-98 BC.....	18
Turbine TE-95 RM / TE-97 RM / TE-98 RM .....	19
<b>4. Operation</b> .....	20
Assembly/Removal Quick coupling.....	20
Assembly/Removal Turbine .....	22
To change rotary instrument .....	27
Test run .....	28
<b>5. Hygiene and maintenance</b> .....	29
General notes .....	29
Limitations on processing.....	31
Initial treatment at the point of use.....	32
Manual cleaning.....	33

Manual disinfection .....	36
Drying .....	38
Inspection, Maintenance and Testing .....	39
Turbine packaging .....	44
Sterilization .....	45
Storage.....	48
<b>6. Maintenance .....</b>	<b>49</b>
Replacing the rotor .....	49
Cleaning/Replacing the water filter .....	51
Replacing the generator .....	53
Replacing the O-rings .....	55
<b>7. Troubleshooting .....</b>	<b>56</b>
<b>8. Servicing .....</b>	<b>58</b>
<b>9. Accessories, consumables, spare parts and other recommended medical devices by W&amp;H.....</b>	<b>59</b>
<b>10. Technical data .....</b>	<b>60</b>
<b>11. Information on electromagnetic compatibility according to IEC/EN 60601-1-2 .....</b>	<b>65</b>
<b>12. Disposal.....</b>	<b>68</b>
<b>Explanation of warranty terms.....</b>	<b>69</b>
<b>Authorized W&amp;H service partner .....</b>	<b>71</b>

## Symbols



**WARNING!**  
(risk of injury)



**ATTENTION!**  
(to prevent  
damage occurring)



General explanations,  
without risk to  
persons or objects



Do not dispose of with  
domestic waste



UL Component Recognition  
Mark indicates compliance  
with Canadian and U.S.  
requirements



DataMatrix Code  
for product information  
including UDI (Unique  
Device Identification)

**R<sub>x</sub>**<sub>only</sub>

Caution! Federal law restricts this device to sale by or on the order of a dentist, physician, veterinarian or with the descriptive designation of any other practitioner licensed by the law of the State in which the practitioner practices to use or order the use of the device.

## Symbols



CE marking  
with identification number  
of the Notified Body



Sterilizable up to the stated  
temperature



Data structure in  
accordance with Health  
Industry Bar Code



Consult Instructions for use



Thermo washer disinfectable



Date of manufacture



Catalogue number



Medical Device



Manufacturer



Serial number



Type B applied part (not suitable  
for intracardiac application)

## 1. Introduction

---

Customer satisfaction has absolute priority in the W&H quality policy. This medical device has been developed, manufactured and subjected to final inspection according to legal regulations, quality and industry standards.

### **For your safety and the safety of your patients**

Prior to initial use please read the Instructions for use. These explain how to use your medical device and guarantee a smooth and efficient operation.



Observe the safety notes.

### **Intended use**

The dental turbine handpiece is intended for the following applications: Removal of decayed materials, cavities and crown preparation, removal of fillings, finishing of tooth and restoration surfaces.

The coupling is intended for the following applications: Connector for media transfer (air, water, electricity and/or light) between the supply hose of the dental unit and air driven handpieces.



Misuse may damage the medical device and hence cause risks and hazards for patient, user and third parties.



### **Qualifications of the user**

We have based our development and design of the medical device on the dentists, dental hygienists, dental employees (prophylaxis) and dental assistants target group.

## **Responsibility of the manufacturer**

The manufacturer can only accept responsibility for the safety, reliability and performance of the medical device when it is used in compliance with the following directions:

- > The medical device must be used in accordance with these Instructions for use.
- > Only the components approved by the manufacturer may be replaced (rotor, O-rings, generator and water filter).
- > Modifications or repairs must only be undertaken by an authorized W&H service partner (see page 71).
- > Correct the malfunction as described in the instruction for use.



### **Skilled application**

The medical device is intended only for skilled application according to the intended use as well as in compliance with the valid health and safety at work regulations, the valid accident prevention regulations and in compliance with these Instructions for use.

The medical device should be prepared for use and maintained by staff who have been trained in procedures for infection control, personal safety and patient safety.

Improper use, (e.g., through poor hygiene and maintenance), non-compliance with our instructions or the use of accessories and spare parts which are not approved by W&H, invalidates all claims under warranty and any other claims.



Any serious incident that has occurred in relation to the medical device should be reported to the manufacturer and the competent authority!

## 2. Safety notes

---



- > The operation of the medical device is permitted only on supply units which correspond to the standards IEC 60601-1 (EN 60601-1) and IEC 60601-1-2 (EN 60601-1-2).
- > Before using the medical device for the first time, store it at room temperature for 24 hours.
- > Use only the supply hoses as specified by EN ISO 9168
- > Always ensure the correct operating conditions and cooling function.
- > Always ensure that sufficient and adequate cooling is delivered and ensure adequate suction.
- > In case of coolant supply failure, the medical device must be stopped immediately.
- > Use only the filtered, oil-free and cooled air supplied by dental compressors for drive air
- > Check the medical device for damage and loose parts before each use (e.g. push-button).
- > Do not operate the medical device if it is damaged.
- > Perform a test run before each use.
- > Avoid overheating at the treatment site.



- > Do not use the medical device if there are soft tissue wounds in the mouth. The air pressure can cause septic substances to enter the tissue or trigger embolisms.
- > Do not lift the cheek or tongue with the medical device. Risk of burning due to the push-button heating up!
- > It is imperative to comply with the concentrations and exposure times specified by the manufacturer of the treatment water decontamination system, as well as its handling.
- > Do not use the medical device as a light probe.
- > Do not look directly into the light source.
- > The Quick coupling is a functional part of the supply hose and should therefore also be seen as an extension to it during reprocessing. It is imperative to comply with the concentrations and exposure times specified by the manufacturer of the treatment water decontamination system, as well as its handling.

If the Quick coupling is processed separately from the supply hose, you can refer to the information in the chapter “Hygiene and maintenance” as per ISO 17664 from the manufacturer of the quick coupling.



### **Risks due to electromagnetic fields**

TE-97 LQ, TE-98 LQ, RQ-53, RQ-54

The functionality of active implantable medical devices (AIMD) (e.g. cardiac pacemaker, ICD) can be affected by electric, magnetic and electromagnetic fields.

- > Find out if the patient has active implantable medical devices (AIMD) before using the medical device and inform about the risks.
- > Do not place the applied part on the patient's body.

## Hygiene and maintenance prior to initial use



- > The medical device is sealed in PE film and not sterilized when delivered.
- > The PE film and the packaging are non-sterilizable.



- > Clean, disinfect and lubricate the medical device.
- > Sterilize the turbine and the nozzle cleaner.

### 3. Product description

### Quick coupling with generator

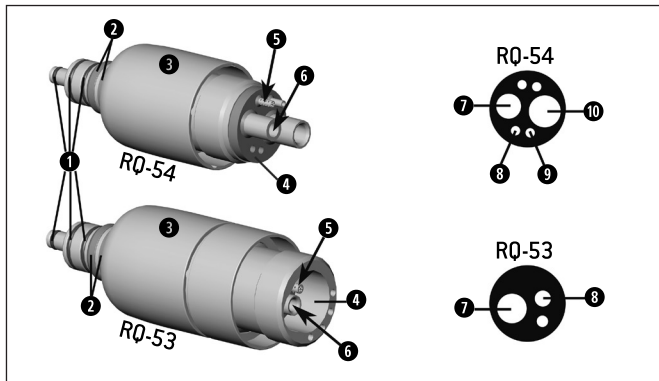

#### RQ-53 / RQ-54

- ① O-rings
- ② Electrical contacts
- ③ Nut
- ④ Gasket
- ⑤ Water filter with resuction stop
- ⑥ Generator

#### Connections

- ⑦ Drive air
- ⑧ Water
- ⑨ Spray air
- ⑩ Exhaust



All Quick couplings are equipped with a non-retraction valve which prevents contaminated cooling water from being sucked back into the turbine and the supply hose.

The non-retraction valve is integrated in the cooling water supply system.

In the event of blocked or incorrectly routed cooling water lines, please contact an authorized W&H service partner (see page 71).



The cooling water lines must not be cleaned with sharp objects!

(This could damage the sealing element and prevent the non-retraction valve from working.)

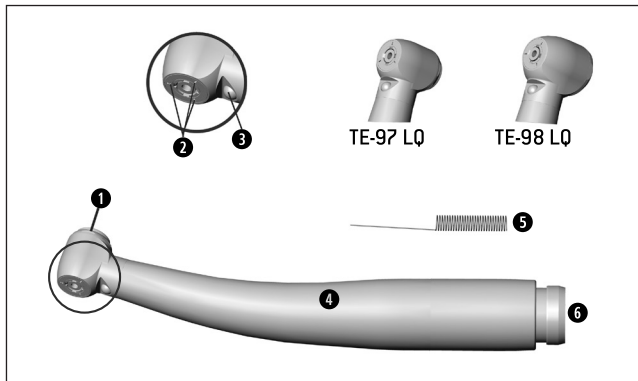

- 1 Push-button
- 2 Spray nozzles
- 3 Light source (LED)
- 4 Sheath
- 5 Nozzle cleaner
- 6 Roto Quick connection

 The turbine handpiece TE-97 LQ / TE-98 LQ may only be used with the Quick coupling RQ-53 / RQ-54.

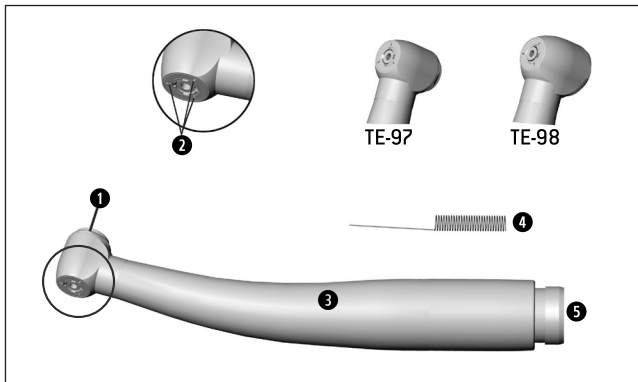

- 1 Push-button
- 2 Spray nozzles
- 3 Sheath
- 4 Nozzle cleaner
- 5 Roto Quick connection

## Product description

Turbine TE-95 BC / TE-97 BC / TE-98 BC

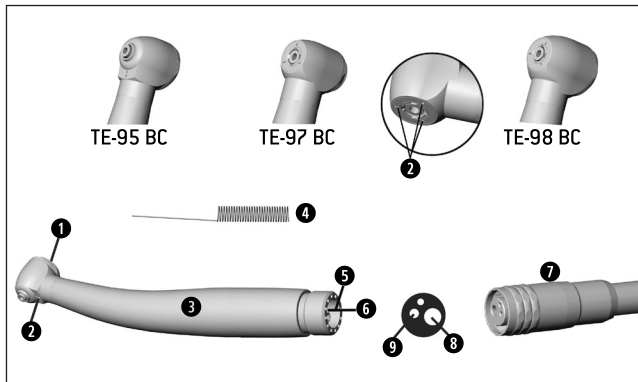

- 1 Push-button
- 2 Spray nozzles
- 3 Sheath
- 4 Nozzle cleaner
- 5 Gasket
- 6 Water filter with resuction stop
- 7 Supply hose

### Connections

- 8 Drive air
- 9 Water

## Product description

Turbine TE-95 RM / TE-97 RM / TE-98 RM

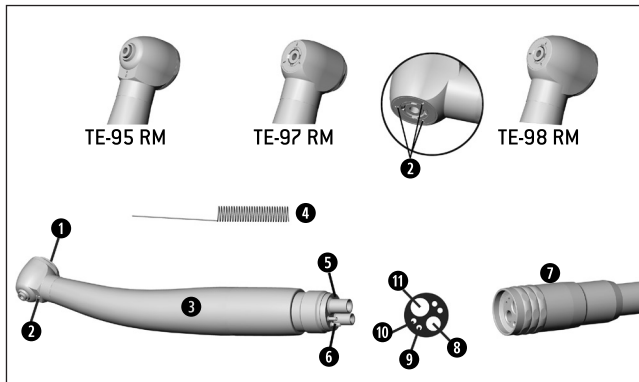

- ① Push-button
- ② Spray nozzles
- ③ Sheath
- ④ Nozzle cleaner
- ⑤ Gasket
- ⑥ Water filter with resuction stop
- ⑦ Supply hose

### Anschlüsse

- ⑧ Drive air
- ⑨ Water
- ⑩ Spray air
- ⑪ Exhaust

## 4. Operation

### Assembly/Removal Quick coupling

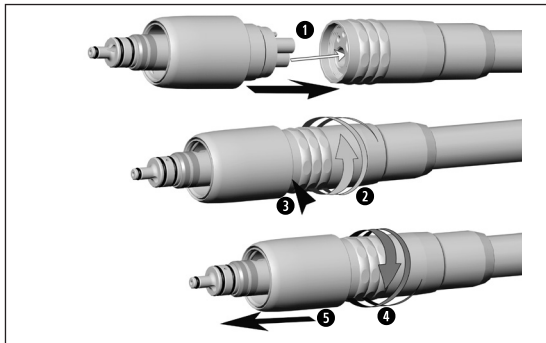

#### RQ-53 / RQ-54

- 1 Connect the Quick coupling to the supply hose.
- 2 Firmly tighten the union nut of the supply hose by hand in a clockwise direction to ensure there are no leaks.



- 3 Verify full engagement.  
Check the leak tightness.

or

- 4 Unscrew the union nut.
- 5 Remove the Quick coupling from the supply hose.



This method of assembly provides a connection for drive air, chip air, return air, water and electricity.

### Checking the Quick coupling for leak



- > Push an appropriate air driven medical device onto the Quick coupling.
- > Activate the medical device, or if possible just activate the spray water only.
- > No water should leak between the Quick coupling and the air driven medical product, and the coupling and the supply hose.

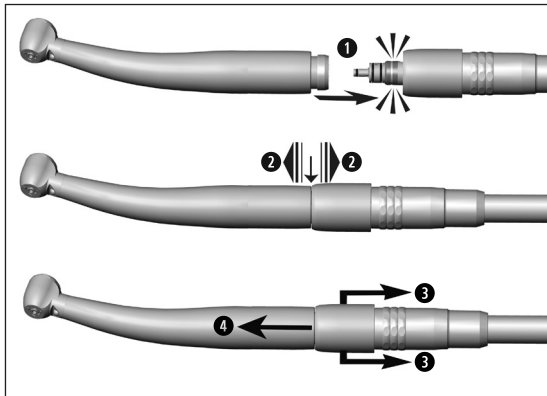

## TE-97 LQ / TE-98 LQ / TE-97 / TE-98



Do not assemble or remove the medical device during the operation!

- ① Push the turbine handpiece onto the Quick coupling.



- ② Verify full engagement.

or

- ③ Pull the retention sleeve of the Quick coupling back.
- ④ Remove the turbine handpiece by pulling in an axial direction.



- > Always follow recommendations made by the manufacturer of air driven products.
  - > Only connect air driven product with appropriate connection to the Quick coupling.
  - > The user accepts sole responsibility if other air driven products are used.
- We accept no liability in such cases.

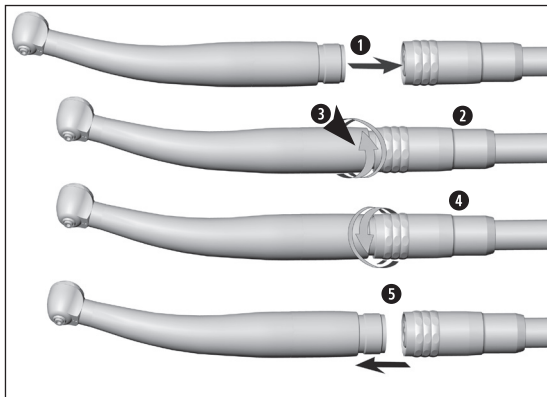

## TE-95 BC / TE-97 BC / TE-98 BC



Do not assemble or remove the medical device during operation!

- ① Insert the turbine handpiece into the apertures of the supply hose.
- ② Screw the union nut on.



- ③ Verify full engagement.  
Check the leak tightness

or

- ④ Unscrew on the union nut.
- ⑤ Remove the turbine handpiece from the supply hose.

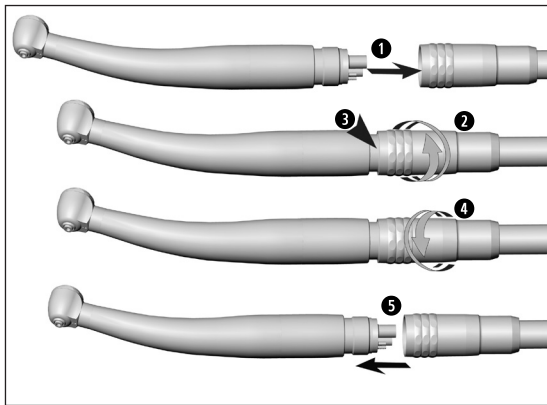

## TE-95 RM / TE-97 RM / TE-98 RM



Do not assemble or remove the medical device during operation!

- ① Insert the turbine handpiece into the apertures of the supply hose.
- ② Screw the union nut on.



- ③ Verify full engagement. Check the leak tightness

or

- ④ Unscrew on the union nut.
- ⑤ Remove the turbine handpiece from the supply hose.

## Rotary instruments



- > Use only rotary instruments which are in perfect condition. Follow the operating instructions of the manufacturer
- > Insert the rotary instrument only when medical device is stationary.
- > Never touch the rotary instrument while it is still rotating.
- > Do not activate the push-button of the medical device during operation. This leads to detachment of the rotary instrument, damage to the chucking system and/or heating up of the medical device. Risk of burning!
- > Only use rotary instruments up to the maximum operating speed stipulated by the manufacturer.

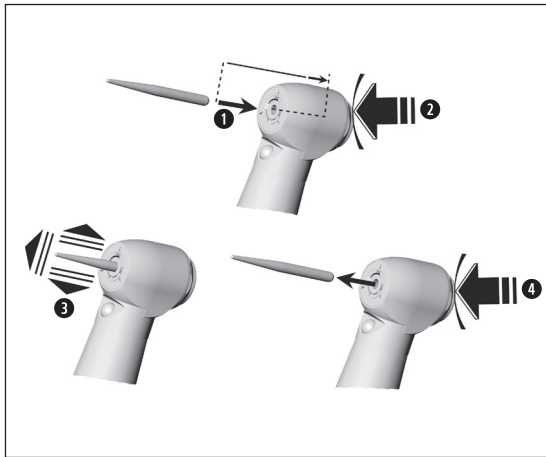

## To change rotary instrument

- 1** Insert the rotary instrument.
- 2** Activate push-button, at the same time insert the rotary instrument until back stop.



- 3** Verify full engagement.

or

- 4** Remove the rotary instrument by pushing the push-button.

## Test run



Do not hold the medical device at eye level!

- > Insert the rotary instrument.
- > Start the medical device.



In the event of operating malfunctions (e.g., vibrations, unusual noise, overheating, coolant failure or leakage) stop the medical device immediately and contact an authorized W&H service partner.



Follow your local and national laws, directives, standards and guidelines for cleaning, disinfection and sterilization.



> The information on the validated reprocessing procedures serves as an example of an ISO 17664 compliant processing of the medical device.



- > Wear protective clothing, safety glasses, face mask and gloves.
- > Couplings are considered an extension of the tubing. Clean and disinfect without disconnecting from the tubing using an intermediate, hospital grade disinfectant after each patient.
- > Use only oil-free, filtered compressed air with a maximum operating pressure of 3 bar (43.5 psi) for manual drying.

## Cleaning agents and disinfectants



- > Read the notes, follow the instructions and heed the warnings provided by the manufacturers of cleaning agents and/or disinfectants.
- > Use only detergents which are intended for cleaning and/or disinfecting medical devices made of metal and plastic.
- > It is imperative to comply with the concentrations and exposure times specified by the manufacturer of the disinfectant.
- > Use disinfectants which have been tested and found effective by, for example: the Verbund für Angewandte Hygiene e.V. (VAH = Association for Applied Hygiene), the Österreichischen Gesellschaft für Hygiene, Mikrobiologie und Präventivmedizin (ÖGHMP = Austrian Society for Hygiene, Microbiology and Preventive Medicine), the Food and Drug Administration (FDA) or the U.S. Environmental Protection Agency (EPA).



The user is responsible for validating its process if the specified cleaning agents and disinfectants are not available.



The product lifetime and the medical device's ability to operate correctly are mainly determined by mechanical stress during use and chemical influences due to processing.

- > Send worn or damaged medical devices and/or medical devices with material changes to an authorized W&H service partner.

### Processing cycles



- > We recommend a regular service for the W&H medical device after 1,000 processing cycles or one year.

### Quick coupling

- > In the case of wipe disinfection, the use of the medical device is guaranteed without restriction until a functional or material limitation is recognizable.



Clean the medical device immediately after every treatment, to flush out liquid (e.g., blood, saliva etc.) and to prevent settling on the internal parts.



### **Turbine**

- > Operate the medical device for at least 10 seconds at idle speed.
- > Ensure that all outlets are rinsed out.
- > Wipe the entire surface of the medical device with disinfectant.
- > Remove the rotary instrument.
- > Remove the turbine from the supply hose



### **Quick coupling**

- > Wipe the entire surface of the medical device with disinfectant.
- > If the Quick coupling remains on the supply hose, follow the instructions of the unit manufacturer.



Note that the disinfectant used during pre-treatment is only for personal protection and cannot replace the disinfectant step after cleaning.

## Manual cleaning



Do not place the medical device in liquid disinfectant or in an ultrasonic bath!

- > Clean the medical device under running tap water (<35°C / 95°F).
- > Rinse and brush off all internal and external surfaces.
- > Move moving parts back and forth several times.
- > Remove any liquid residues using compressed air.

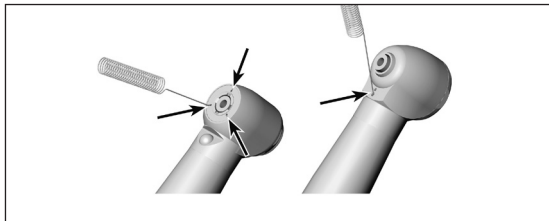

### **Cleaning of the spray nozzles**

- > Clean coolant outlets carefully with the nozzle cleaner to remove dirt and deposits



Clean and disinfect the nozzle cleaner in an ultrasonic bath and/or in the washer disinfectant.

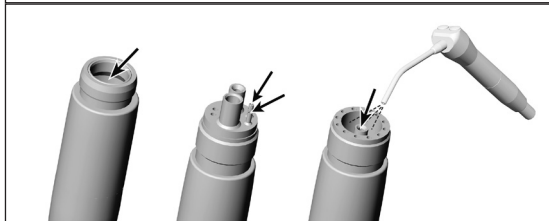

### **Cleaning of the coolant tubes**

- > Blow through the coolant tube using compressed air.



In case of blocked coolant outlets or coolant tubes contact an authorized W&H service partner.

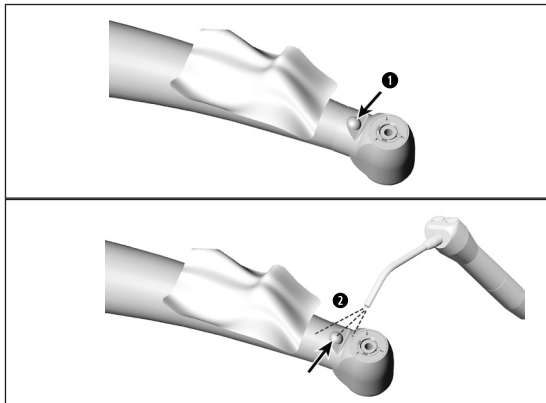

## TE-97 LQ / TE-98 LQ Cleaning of the light source



**Avoid scratching of the light source!**

- 1 Wash the light source with cleaning fluid and a soft cloth.
- 2 Blow the light source dry using compressed air or dry it with a soft cloth.



- > Carry out a visual inspection after each cleaning process.
- > Do not use the medical device if the light source is damaged and contact an authorized W&H service partner.



> W&H recommends wiping down with disinfectant.



Evidence of the medical device's basic suitability for effective manual disinfection was provided by an independent test laboratory using the disinfectants "mikrozid® AF wipes" (Schülke & Mayr GmbH, Norderstedt) and "CaviWipes™" (Metrex).



W&H recommends automated cleaning and disinfection using a washer-disinfector (WD).

- > Read the notes, follow the instructions and heed the warnings provided by the manufacturers of washer-disinfectors, cleaning agents and/or disinfectants.



Evidence of the medical device's basic suitability for effective automated disinfection was provided by an independent test laboratory using the "Miele PG 8582 CD" washer-disinfector (Miele & Cie. KG, Gütersloh) and the "Dr. Weigert neodisher® MediClean forte" cleaning agent (Dr. Weigert GmbH & Co. KG, Hamburg) according to ISO 15883.

- > Cleaning at 55°C (131°F) – 5 minutes
- > Disinfection at 93°C (200°F) – 5 minutes



### **Quick coupling RQ-53 / RQ-54**

The medical device is not approved for automated cleaning and disinfection.



- > Ensure that the medical device is completely dry internally and externally after cleaning and disinfection.
- > Remove any liquid residues using compressed air.

### Inspection



- > Check the medical device after cleaning and disinfection for damage, visible residual soiling and surface changes.
- > Reprocess any medical devices that are still soiled.
- > Sterilize the turbine following cleaning, disinfection and lubrication.

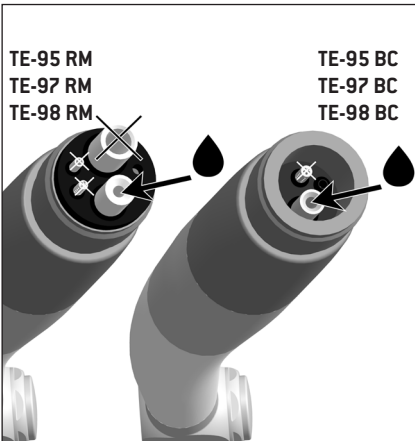

### Turbine lubrication



- > Lubricate the dry medical device immediately after cleaning and/or disinfection.
- > Direct the medical device downwards.

### Recommended lubrication cycles

- > Essential after every internal cleaning
  - > Before each sterilization
- or
- > After 30 minutes of use or at least once daily
  - > Chucking system once a week

### With W&H Service Oil F1, MD-400

- > Follow the instructions on the oil spray can and on the packaging.
- or

### With W&H Assistina

- > Follow the instructions in the Assistina Instructions for use.

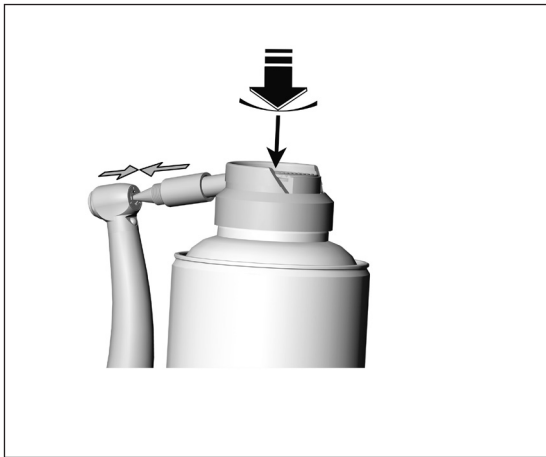

## Lubrication of the chucking system

### With W&H Service Oil F1, MD-400

- > Fit the spray adaptor REF 02036100 onto the spray can.
- > Hold the medical device firmly.
- > Press the tip of the spray adaptor firmly into the chucking system
- > Spray for approx. 1 second.

or

### With W&H Assistina

- > Follow the instructions in the Assistina Instructions for use.

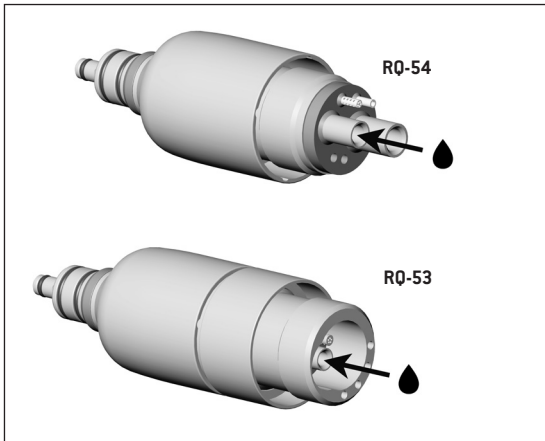

## Lubrication of the generator (coupling)

### Recommended lubrication cycles



- > Oil the generator of the Roto Quick coupling once a month in order to ensure that the light continues to operate.
- > Direct the medical device downwards.

see chapter “Maintenance”

### With W&H Service Oil F1, MD-400

- > Follow the instructions on the oil spray can and on the packaging.

or

### With W&H Assistina

- > Follow the instructions in the Assistina Instructions for use.

## Test after lubrication



- > Direct the medical device downwards.
- > Operate the medical device so that excess oil can escape.
- > Remove any oil that has escaped.



Pack the medical device and the accessories in sterilization packages that meet the following requirements:

- > The sterilization package must meet the applicable standards in respect of quality and use and must be suitable for the sterilization method.
- > The sterilization package must be large enough for the sterilization goods.
- > The filled sterilization package must not be under tension.



W&H recommends sterilization according to EN 13060, EN 285 oder ANSI/AAMI ST55.



- > Read the notes, follow the instructions and heed the warnings provided by the manufacturers of steam sterilizers.
- > The program selected must be suitable for the medical device.



- > The medical device RQ-53, RQ-54 is not suitable for sterilization.

### **Recommended sterilization procedures**

- > “Dynamic-air-removal prevacuum cycle” (type B) / “Steam-flush pressure-pulse cycle” (type S)\*/\*\*  
134°C (273°F) for at least 3 minutes, 132°C (270°F) for at least 4 minutes
- > “Gravity-displacement cycle” (type N)\*\*  
121°C (250°F) for at least 30 minutes
- > Maximum sterilization temperature 135°C (275°F)



Evidence of the medical device's basic suitability for effective sterilization was provided by an independent test laboratory using the LISA 517 B17L\* steam sterilizer (W&H Sterilization S.r.l., Brusaporto (BG)), the Systec VE-150\* steam sterilizer (Systec) and the CertoClav MultiControl MC2-S09S273\*\* steam sterilizer (CertoClav GmbH, Traun).

“Dynamic-air-removal prevacuum cycle” (type B): 134°C (273°F) – 3 minutes\*, 132°C (270 °F) – 4 minutes\*/\*\*  
“Steam-flush pressure-pulse cycle” (type S): 134°C (273°F) – 3 minutes\*, 132°C (270 °F) – 4 minutes\*/\*\*  
“Gravity-displacement cycle” (type N): 121°C (250°F) – 30 minutes\*\*

Drying times:

“Dynamic-air-removal prevacuum cycle” (type B): 132°C (270°F) – 30 minutes\*\*  
“Steam-flush pressure-pulse cycle” (type S): 132°C (270°F) – 30 minutes\*\*  
“Gravity-displacement cycle” (type N): 121°C (250°F) – 30 minutes\*\*

\* EN 13060, EN 285, ISO 17665

\*\* ANSI/AAMI ST55, ANSI/AAMI ST79



- > Store sterile goods dust-free and dry.
- > The shelf life of the sterile goods depends on the storage conditions and type of packaging.



- > The Quick coupling may be stored on the supply hose.

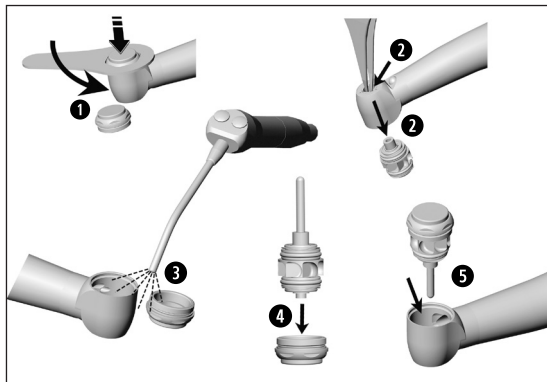

- 1 Unscrew the push-button using the hexagon wrench.
  - 2 Push the rotor out of the turbine head using the tip of a pair of tweezers.
-  Clean the inside of the turbine head and the push-button with a cloth soaked in isopropyl alcohol.
- 3 Blow dry the push-button and the turbine head with compressed air
  - 4 Place the new rotor into the push-button.
  - 5 Place the rotor with the push-button into the turbine head.

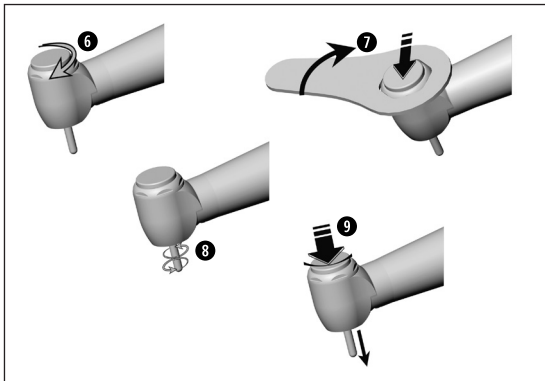

- ⑥ Screw the push-button onto the turbine head.
- ⑦ Tighten the push-button using the hexagon wrench.
- ⑧ Check free running of the rotor.
- ⑨ Activate the push-button and remove the mandrel.



> Repeat the complete hygiene and maintenance process.

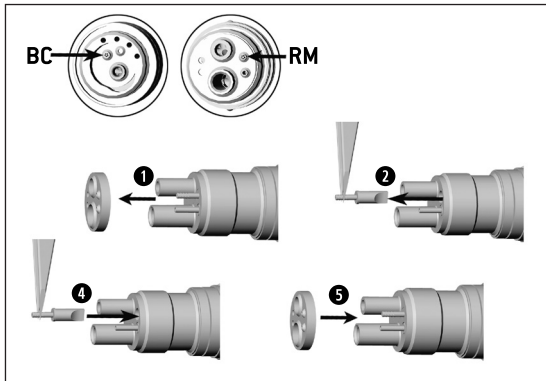

## Cleaning/Replacing the water filter

RQ-53 / RQ-54

TE-95 BC / RM, TE-97 BC / RM, TE-98 BC / RM

- 1 Remove the gasket.
- 2 Pull the water filter out using a pair of tweezers.
- 3 Clean the water filter.

or

- 4 Insert a new water filter.
- 5 Slide on the gasket.

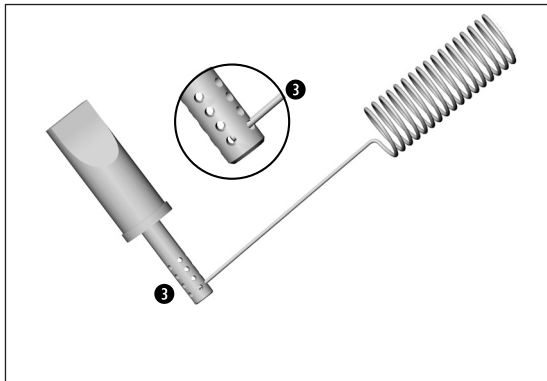

## Cleaning the water filter

- 3 Clean outlets carefully with the nozzle cleaner to remove dirt and deposits.



The water filter can be cleaned in an ultrasonic bath.



> Repeat the complete hygiene and maintenance process.

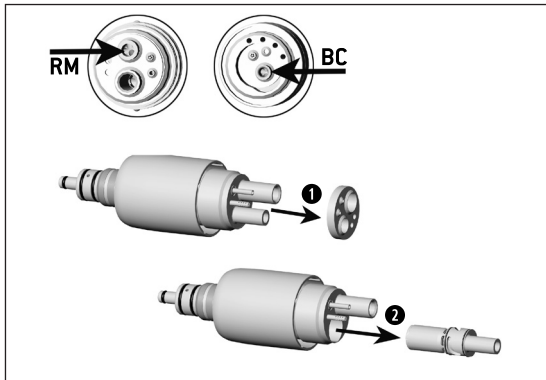

## Replacing the generator RQ-53 / RQ-54

- 1 Remove the gasket.
- 2 Pull out the old generator.

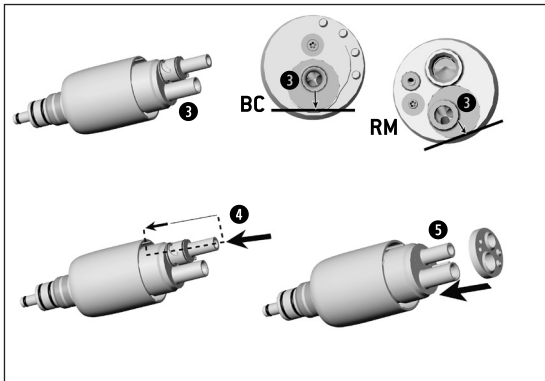

- 3 Position the new generator with the mark aligned with the notch on the Quick coupling.
- 4 Insert the new generator until back stop.
- 5 Slide on the gasket.



> Repeat the complete hygiene and maintenance process.

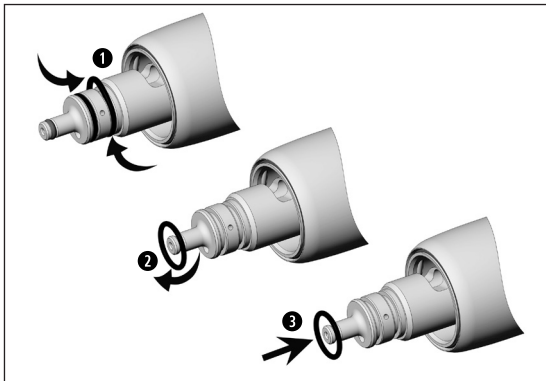

## Replacing the O-rings (RQ-53 / RQ-54)



- > Replace damaged or leaking O-rings immediately.
- > Always replace all the O-rings.
- > Do not use a sharp tool!

- ① Squeeze the O-ring between your thumb and index finger so that it forms a loop.
- ② Pull off the O-ring.
- ③ Push the new O-ring on in place.



If it proves impossible to correct the malfunction, please contact an authorized W&H service partner.



- > Repeat the complete hygiene and maintenance process.

## 7. Troubleshooting

Malfunction	Correction of malfunction
Insufficient power	<ul style="list-style-type: none"><li>&gt; Check the connection between the turbine handpiece /Quick coupling and supply hose</li><li>&gt; Check the operating pressure</li><li>&gt; Perform an oil service</li><li>&gt; Check/replace the O-rings</li><li>&gt; Replace the rotor</li></ul>
Insufficient/no cooling	<ul style="list-style-type: none"><li>&gt; Check the operating pressure</li><li>&gt; Clean the spray nozzles</li><li>&gt; Clean/replace the water filter</li><li>&gt; Check/replace the O-rings</li></ul>

## Troubleshooting

Malfunction	Correction of malfunction
Inadequate hold of rotary instrument	<ul style="list-style-type: none"><li>&gt; Perform an oil service</li><li>&gt; Replace the push-button</li><li>&gt; Replace the rotor</li></ul>
<p><b>Insufficient/no light</b></p>  Attach another LED turbine handpiece to determine whether the LED on the turbine handpiece or the generator in the Quick coupling is defective.	<ul style="list-style-type: none"><li>&gt; Check the operating pressure</li><li>&gt; Perform an oil service</li><li>&gt; Lubricate the generator</li><li>&gt; Replace the generator</li></ul>

## 8. Servicing

---

### Repairs and returns

In the event of operating malfunctions immediately contact an authorized W&H service partner.

Repairs must only be undertaken by an authorized W&H service partner.



> Ensure that the medical device has been completely processed before returning it.

## 9. Accessories, consumables, spare parts and other recommended medical devices by W&H

---



Use only original W&H accessories and spare parts or accessories approved by W&H.

**Suppliers: W&H partners**

Scan the QR code to find accessories, consumables and spare parts for this medical device.



## 10. Technical data

Turbine		TE-98 / TE-98 LQ	TE-97 / TE-97 LQ
Connection		W&H Roto Quick	
Rotary instruments	ISO 1797 (Ø mm)	1.6 – 0.01	
Maximum length approved by W&H **	(mm)	25	21
Minimum chucking length		until back stop	
Maximum operating part diameter	(mm)	2	
Maximum idle mode speed ( $\pm 30,000 \text{ min}^{-1}$ )	( $\text{min}^{-1}$ )	330,000	390,000
Coolant volume	ISO 14457 (ml/min)	> 50	
Chip air consumption at 2 bar / 29 psi	(NI/min)	> 1.5	
Water setting range (Recommended water pressure) ***	(bar/psi)	0.7 – 2 (1.5) bar / 10.2 – 29 (21.8) psi	
Chip air setting range (Recommended chip air pressure)	(bar/psi)	1.5 – 3 (2) bar / 21.8 psi – 43.5 (29) psi	
Exhaust pressure	(bar/psi)	< 0.5 bar / < 7.3 psi	
Operating pressure range	(bar/psi)	2.2 – 2.8 bar / 32 - 40.6 psi	
Recommended operating pressure	(bar/psi)	2.5 bar / 36.3 psi	
Air consumption	(NI/min)	30 – 45	

\* see page 63

$\text{min}^{-1}$  (Revolutions per minute)

## Technical data

Turbine		TE-95 BC / TE-98 BC	TE-97 BC
Connection according to standard	EN ISO 9168:2009	Type 1: Borden 2-hole	
Rotary instruments	ISO 1797 (Ø mm)	1.6 – 0.01	
Maximum length approved by W&H **	(mm)	25	21
Minimum chucking length		until back stop	
Maximum operating part diameter	(mm)	2	
Maximum idle mode speed ( $\pm 30,000 \text{ min}^{-1}$ )	( $\text{min}^{-1}$ )	330,000	390,000
Coolant volume	ISO 14457 (ml/min)	> 50	
Chip air consumption at 2 bar / 29 psi	(NI/min)	> 1.5	
Water setting range (Recommended water pressure) ***	(bar/psi)	0.7 – 2 (1.5) bar / 10.2 – 29 (21.8) psi	
Chip air setting range (Recommended chip air pressure)	(bar/psi)	1.5 – 3 (2) bar / 21.8 psi – 43.5 (29) psi	
Exhaust pressure	(bar/psi)	< 0.5 bar / < 7.3 psi	
Operating pressure range	(bar/psi)	2.2 – 2.8 bar / 32 - 40.6 psi	
Recommended operating pressure	(bar/psi)	2.5 bar / 36.3 psi	
Air consumption	(NI/min)	30 – 45	

\* see page 63

$\text{min}^{-1}$  (Revolutions per minute)

## Technical data

Turbine		TE-95 RM / TE-98 RM	TE-97 RM
Connection according to standard	EN ISO 9168:2009	Type 3: Standard 4-hole	
Rotary instruments	ISO 1797 (Ø mm)	1.6 – 0.01	
Maximum length approved by W&H**	(mm)	25	21
Minimum chucking length		until back stop	
Maximum operating part diameter	(mm)	2	
Maximum idle mode speed ( $\pm 30,000 \text{ min}^{-1}$ )	( $\text{min}^{-1}$ )	330,000	390,000
Coolant volume	ISO 14457 (ml/min)	> 50	
Chip air consumption at 2 bar / 29 psi	(NI/min)	> 1.5	
Water setting range (Recommended water pressure) ***	(bar/psi)	0.7 – 2 (1.5) bar / 10.2 – 29 (21.8) psi	
Chip air setting range (Recommended chip air pressure)	(bar/psi)	1.5 – 3 (2) bar / 21.8 psi – 43.5 (29) psi	
Exhaust pressure	(bar/psi)	< 0.5 bar / < 7.3 psi	
Operating pressure range	(bar/psi)	2.2 – 2.8 bar / 32 - 40.6 psi	
Recommended operating pressure	(bar/psi)	2.5 bar / 36.3 psi	
Air consumption	(NI/min)	30 – 45	

\* see page 63

$\text{min}^{-1}$  (Revolutions per minute)

## Technical data

Quick coupling		RQ-53	RQ-54
Connection according to standard	EN ISO 9168:2009	Type 1: Borden	Type 3: Ritter Midwest (4-hole)
Recommended operating pressure	(bar/psi)	2.2 – 2.8 bar / 32 - 40.6 psi	

Power and speed data are largely dependent on the quality of the turbine hoses used and may therefore differ from the specified values.

 \*\* When using longer rotary instruments the user must ensure by correct selection of the operating conditions, that there is no danger to the user, patient or third parties.

\*\*\*Chip air pressure / water pressure must be set at the same time  
The chip air pressure must be higher than the water pressure



### **Temperature information**

Temperature of the medical device on the operator side:	maximum 56°C (133°F)
Temperature of the medical device on the patient side (metal):	maximum 51°C (123,8°F)
Temperature of the working part (rotary instrument):	maximum 41°C (105.8°F)

### **Ambient conditions**

Temperature during storage and transport	-40°C to +70°C (-40°F to +158°F)
Humidity during storage and transport	8 % to 80 % (relative), non-condensing
Temperature during operation	+10°C to +35°C (+50°F to +95°F)
Humidity during operation:	15 % to 80 % (relative), non-condensing

## 11. Information on electromagnetic compatibility according to IEC/EN 60601-1-2

---



### **Operating environment and EMC warning notes**

This medical device is neither life-sustaining nor coupled to the patient. It is suitable for operation both in domestic healthcare and in facilities used for medical purposes except rooms/areas, in which EMC interference of high-intensity may occur. The customer and/or the user should assure that this medical device is set up and used in an environment of the specified type and/or in accordance with the specifications of the manufacturer. This medical device uses RF energy only for its internal functions. Therefore, its RF emissions are very low and not likely to cause any interference in nearby electronic equipment.

No special precautions are necessary to maintain the basic safety and essential performance of this medical device.



### **Essential performance**

This medical device has no critical functions and therefore does not have any essential performance features.



### **RF communication equipment**

Portable RF communications equipment (including peripherals such as antenna cables and external antennas) should be used no closer than 30 cm (12 inches) to the medical device. Otherwise, degradation of the performance of this medical device could result.



W&H guarantees the compliance of the device with the EMC requirements only when used with original W&H accessories and spare parts. The use of accessories and spare parts not approved by W&H can lead to an increased emission of electromagnetic interference or to a reduced resistance against electromagnetic interference.



Use of this medical device adjacent to or stacked with other equipment should be avoided because it could result in improper operation. If such use is necessary, this medical device and the other equipment should be observed to verify that they are operating normally.



The medical device is not intended for use in the vicinity of HF surgical devices.

## Results of the electromagnetic tests

Requirement	Class / Test Level*														
<b>Electromagnetic emissions</b>															
Electromagnetic radiation disturbance (Radiated Emissions) CISPR 11/EN 55011 [30 MHz – 1000 MHz]	Group 1 Class B														
<b>Immunity to electromagnetic interference</b>															
Electrostatic discharge (ESD) IEC/EN 61000-4-2	Contact discharge: $\pm 8$ kV Air discharge: $\pm 15$ kV														
Radiated RF electromagnetic fields IEC/EN 61000-4-3 [80 MHz – 2,7 GHz]	10 V/m														
Proximity fields from RF wireless communications equipment IEC/EN 61000-4-3	<table> <tbody> <tr> <td>385 MHz</td> <td>27 V/m</td> </tr> <tr> <td>450 MHz</td> <td>28 V/m</td> </tr> <tr> <td>710/745/780 MHz</td> <td>9 V/m</td> </tr> <tr> <td>810/870/930 MHz</td> <td>28 V/m</td> </tr> <tr> <td>1720/1845/1970 MHz</td> <td>28 V/m</td> </tr> <tr> <td>2450 MHz</td> <td>28 V/m</td> </tr> <tr> <td>5240/5500/5785 MHz</td> <td>9 V/m</td> </tr> </tbody> </table>	385 MHz	27 V/m	450 MHz	28 V/m	710/745/780 MHz	9 V/m	810/870/930 MHz	28 V/m	1720/1845/1970 MHz	28 V/m	2450 MHz	28 V/m	5240/5500/5785 MHz	9 V/m
385 MHz	27 V/m														
450 MHz	28 V/m														
710/745/780 MHz	9 V/m														
810/870/930 MHz	28 V/m														
1720/1845/1970 MHz	28 V/m														
2450 MHz	28 V/m														
5240/5500/5785 MHz	9 V/m														

\*) There are no deviations or facilitations to IEC/EN 60601-1-2.

## 12. Disposal

---



Ensure that the parts are not contaminated on disposal.



Follow your local and national laws, directives, standards and guidelines for disposal.

- > Medical device
- > Waste electrical equipment
- > Packaging

# Explanation of warranty terms

This W&H medical device has been manufactured with great care by highly qualified specialists. A wide variety of tests and controls guarantee faultless operation. Please note that claims under warranty can only be validated when all the directions in the Instructions for use have been followed.

**As manufacturer, W&H is liable for material or manufacturing defects within a warranty period of 12 months from the date of purchase. Accessories and consumables are excluded from the warranty.**

We accept no responsibility for damage caused by incorrect handling or by repairs carried out by third parties not authorized to do so by W&H!

Claims under warranty accompanied by proof of purchase, must be sent to the vendor or to an authorized W&H service partner. The provision of service under warranty extends neither the warranty period nor any other guarantee period.

# 12 months warranty



## Authorized W&H service partner

---

Find your nearest authorized W&H service partner at <http://wh.com>  
Simply go to the menu option “Service” for full details.

Or simply scan the QR code.





**W&H Dentalwerk Bürmoos GmbH**  
**Ignaz-Glaser-Straße 53, 5111 Bürmoos, Austria**

**t +43 6274 6236-0,**  
**office@wh.com**

**f +43 6274 6236-55**  
**wh.com**

**Form-Nr. 50817 AEN**  
**Rev. 006 / 25.09.2024**  
**Subject to alterations**